

Hot Melt

BENCHMARK • AUTOPACK • PROFLEX



**Hot Melt  
Technologies, Inc.**

No One Puts It Together Like HMT.®

An Industry Leader In Handgun And Automatic Hot Melt Applications.



## **Why HMT? We Manufacture Everything You Need To Succeed In Hot Melt... From One Convenient Source.**

Companies across America have made Hot Melt Technologies (HMT®) their "go-to" source for hot melt equipment and expertise. You should, too. Consider ...

Since 1981, HMT has been a leader in the hot melt applications industry. And it's no wonder... because all our systems are based on our innovative ProFlex design concept with modular components to fit precise applications and process requirements.

Tested to withstand the rigors of heavy, industrial operations, our ProFlex, Benchmark and AutoPack hot melt systems continue to set the standard for reliability, ease-of-service and value.

We've also pioneered innovative guns, hoses, and accessories. And have established industry leading after-sale support programs designed to maintain shop-floor productivity... while increasing front office satisfaction. Along the way, we've earned a reputation as the company to call first for help with challenging new installations or upgrades.

So whether you're looking to gain greater efficiency for your product assembly or packaging hot melt operation, or simply seeking to move up from a stapler or stick gun, remember ...

**No One Puts It Together Like HMT.**

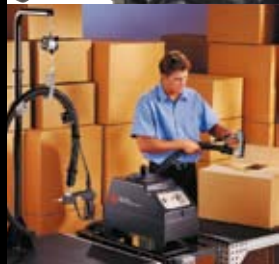
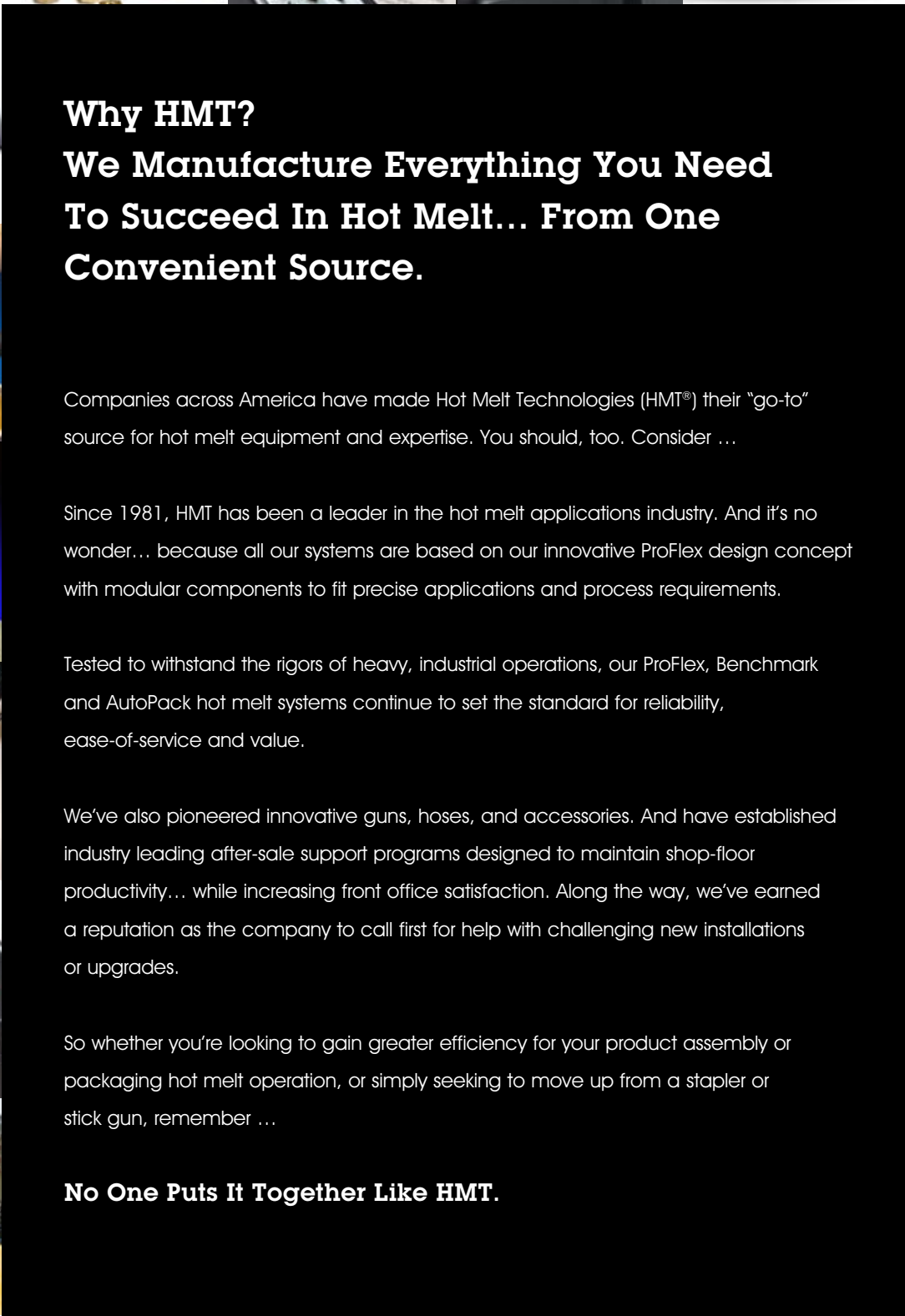
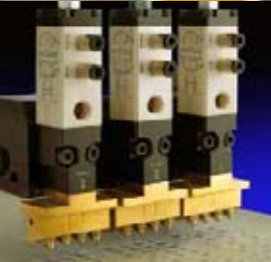

# No Matter The Application... HMT Makes A Hot Melt System That's Just Right For You.

With ProFlex®, Benchmark® and AutoPack™ Systems, no one offers you a greater choice than Hot Melt Technologies.

With ProFlex, we offer full-custom capabilities for high-volume industrial applications. You start with the exact system you want... and go with the reassurance that you can easily replace components to minimize downtime, or reconfigure your system to meet future needs.

We are also setting new standards for reliability and value with our Benchmark and AutoPack Systems. Incorporating many of the production-proven features of our ProFlex models, these systems are pre-configured providing excellent performance, affordability and easy serviceability.

All HMT Hot Melt Systems feature hardened-steel spur gear pumps that provide maximum performance and durability; high-output, fractional-horsepower drive motors designed for continuous duty under the most extreme conditions; patented modular melt tanks designed for quick change and easy cleaning, sophisticated, yet simple-to-operate system and temperature controls.

No matter which HMT system you select, it's a choice you can make with confidence.

## **Benchmark® Hot Melt Systems For Handgun Applications**

Rugged, reliable and easy-to-operate, Benchmark® Hot Melt Systems are pre-configured and value priced. They support one or two handguns, bead or spray applications.



## **AutoPack™ Hot Melt Systems for Packaging and Converting**

AutoPack™ Hot Melt Systems are engineered to offer complete solutions for your automated packaging and converting needs.



## **ProFlex® Hot Melt Systems For High-Performance Industrial Applications**

The ultimate in reconfigurable systems for high-volume applications, ProFlex® Hot Melt Systems are custom-built to meet your individual requirements.



## Pre-Configured, Value-Priced Hot Melt Systems For Handgun Applications.

With Benchmark® Systems, you get the same uncompromised durability, reliability and flexibility you would expect from more expensive, custom-engineered systems yet because Benchmark applicators are pre-configured, they can be offered at an extraordinary value.

Finding the right model is easy. Select one of our general-purpose systems. Or choose one that's specially pre-configured for a specific industry such as woodworking, insulated glass or mattress construction. You can also specify a system that's built for use with a particular type of adhesive such as PUR's, polyamids or butyls.

Whatever your choice, with a Benchmark System you're assured of an applicator that delivers easy set-up, simple-to-use controls and long-lasting performance.



Benchmark 205-LV



Benchmark 215-HV

### Benchmark® 200 Series

Benchmark® 200 Series: Entry-level handgun systems for low-volume hot melt applications with general purpose adhesives: 8-lb. or 15-lb. melt tank capacity; 120 VAC plug-in-the-wall versatility; general packaging and product assembly applications.



Benchmark 535

### Benchmark® 500 Series

Benchmark® 500 Series: Hot melt handgun systems for high-volume applications with high-performance adhesives: Interchangeable melt tanks — 17-, 25-, 35- or 50-lbs.; Viscosity up to 100,000 cP; bead or spray applications.



Benchmark 615



Benchmark 650

### Benchmark® 600 Series

Benchmark® 600 Series: Handgun systems for the application of high viscosity I.G. sealants, mastics, and butyls: 15-lb. or 50-lb. melt tank capacity; viscosity up to 1,000,000 cP.



**HMT Benchmark®  
System Applications  
Include:**

- Appliances
- Automotive
- Bedding
- Cabinet Making
- Construction
- Electronics
- Filters
- Foundry
- Furniture
- HVAC
- Metalworking
- Packaging
- Woodworking
- And, many more ...

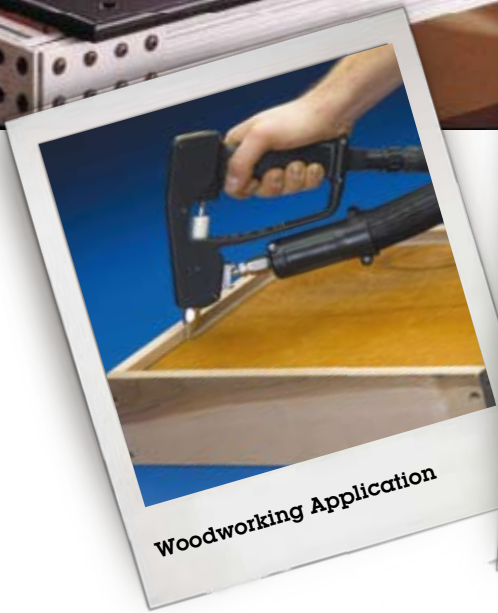

**Woodworking Application**



**Swirl Spray Application**

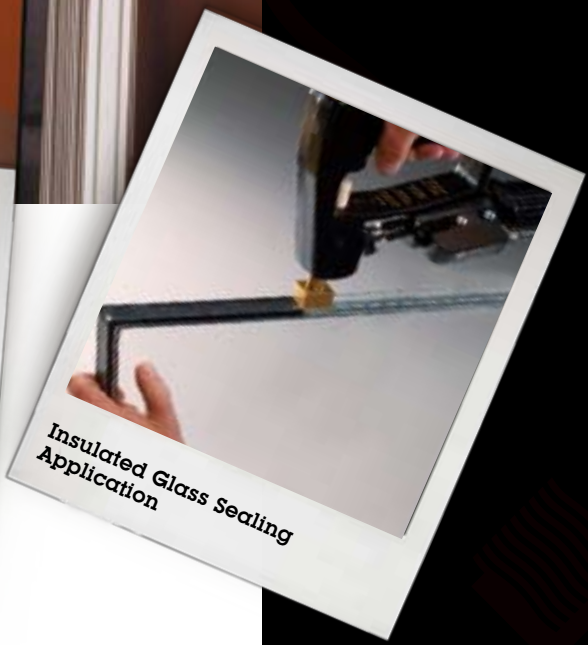

**Insulated Glass Sealing Application**

TM

AutoPack

HOT MELT SYSTEMS

## Specially Designed Systems For Automated Packaging And Converting.

Packagers and converters who are seeking performance, reliability and value can find no better choice than AutoPack™ Systems from Hot Melt Technologies.

Based on our industrial, production-proven ProFlex® and Benchmark® Systems, HMT AutoPack Systems are specially configured for packaging and converting applications.

Offering the combination of an ASU (adhesive supply unit) with electrically driven gear pumps and air-operated guns, there is an AutoPack System to meet your requirements. AutoPack Systems can support the operation of up to four hoses and guns with melt tank capacities from 8 to 85 lbs.

No packaging operation or converting application is too complex. So, whether you are equipping a new operation or replacing an old glue applicator, you can rely on HMT for expert assistance in recommending the AutoPack System that is right for you.



### **AutoPack HP-20**

Shown with heated hose, and high-performance 900 Series guns. Also shown is the HMT DF-224 Pattern Control Timer and attachments.

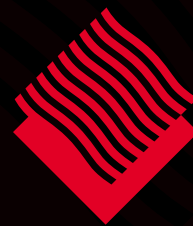

**HMT AutoPack™  
System Applications  
Include:**

- Bag sealing
- Box making
- Carton sealing
- Case closing
- Dunnage assembly
- Envelopes
- Palletizing
- Spout attachments
- Tamper-proof closures
- Tray making
- And, many more ...

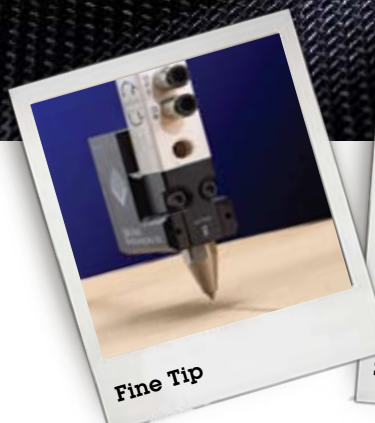

**Fine Tip**



**Swirl Spray**



**Dual Orifice**



**Aimable Low Profile**

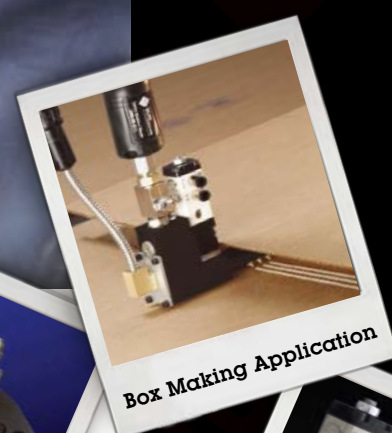

**Box Making Application**



**Multi-Bead**

**A Sampling Of Guns:**

# PROFLEX<sup>®</sup>

HOT MELT SYSTEMS

## Custom-Engineered Systems For High-Volume Industrial Applications.

HMT ProFlex<sup>®</sup> Systems are custom-built to meet your individual needs from a selection of heavy-duty, modular and interchangeable components.

This flexibility means you start with the exact system you want – and proceed with the assurance that you can readily reconfigure it later on to meet your future needs.

In designing a ProFlex<sup>®</sup> System, HMT works with you to evaluate your process and application requirements. Together, we measure your pump output needs, adhesive melt rate and usage rate. We then select the optimum melt tank and determine the correct hose lengths and appropriate guns and nozzles. Advanced, microprocessor-based Genesys<sup>™</sup> System Controls provide simple, secure, and smart operation.



**ProFlex<sup>®</sup> System**  
with a 200-lb melt tank

**ProFlex<sup>®</sup> System**  
with a 135-lb melt tank



## HMT ProFlex® System Applications Include:

- Automotive Assembly
- Foam fabricating
- High-volume bag manufacturing
- Pre-melters for printing
- Robotic and conveyor applications
- Roll forming
- Wide web coating
- Woodworking
- And, many more ...

High-Volume Wide Web Spray Application



Foot Switch Activated, Timed Shot Automatic Application

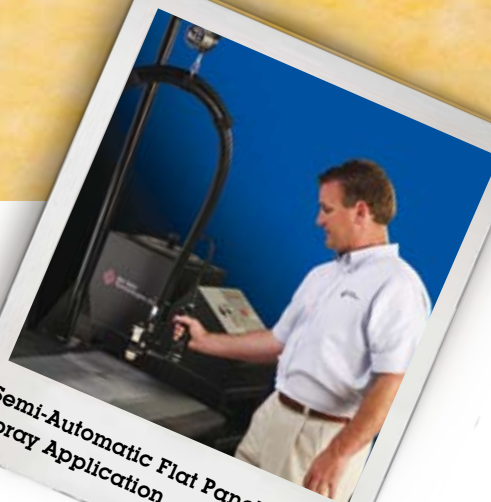

Semi-Automatic Flat Panel Spray Application

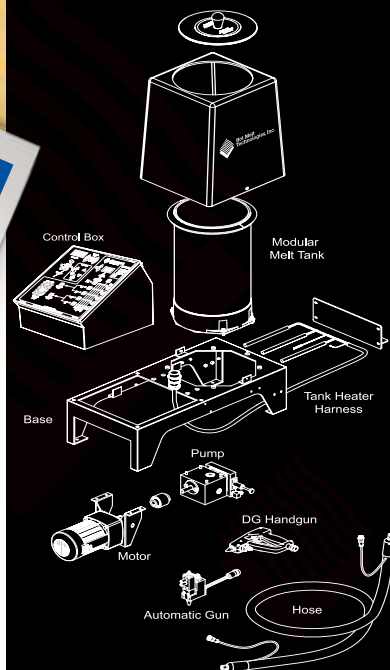

## Single-Source Convenience For All Your Hot Melt Requirements.

### Heated Hoses

HMT Heated Hoses come in lengths up to 24 feet with core diameters of 3/8, 1/2 or 5/8 inches.



### Accessories

Single-shot timers; multi-function pattern control timers; 24-hour/7-day on/off schedulers and other HMT accessories can improve productivity and increase safety.

### Nozzles

Interchangeable HMT Nozzles for handguns and automatic guns are available in every type, including bead, spray, extended, slot, multi-bead and many more.

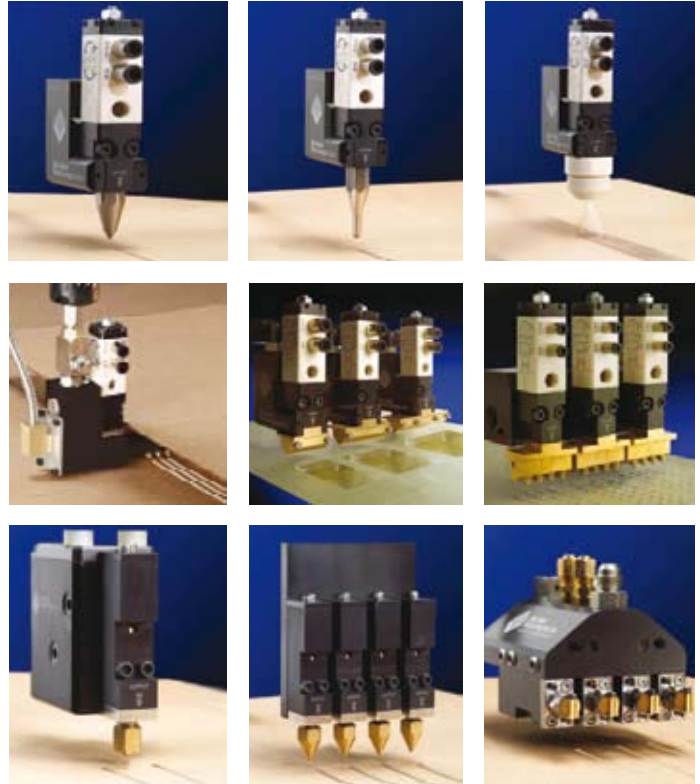

### Automatic Guns

Production-proven, HMT Automatic Guns bring reliability and efficiency to heavy-duty product assembly as well as high-volume packaging and converting applications.

### Handguns

Ergonomically designed to reduce operator fatigue and weighing less than 1 1/2 pounds, HMT Handguns feature 360° linear swivels or 360-PLUS® Ball Swivels: corded and cordless.



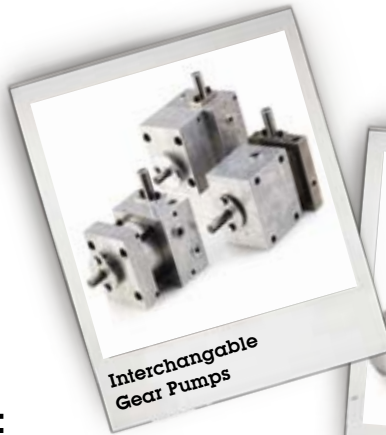

Interchangeable  
Gear Pumps



Interchangeable  
Tank Sizes



Interchangeable Constant  
and Variable-Speed Motors

## Hot Melt Technologies: A Choice You Can Make With Confidence.

HMT is the "go-to" source for many of America's leading manufacturers and packagers. They know our ProFlex<sup>®</sup>, Benchmark<sup>®</sup> and AutoPack<sup>™</sup> Hot Melt Systems are:

### Designed for serviceability ...

With their modular and interchangeable components, our systems are not only built tough for long service life, but also designed for fast and easy serviceability.

### And, fully supported after the sale.

All of our systems are backed by comprehensive warranties and industry-leading after-the-sale service programs. Our DFS<sup>®</sup> (Designed For Serviceability) Repair & Assembly Kits are the surest way we know to minimize downtime. And, our exclusive NXP<sup>®</sup> (New Exchange Program) lets you exchange used components for new ones ... at rebuilt prices.



DFS<sup>®</sup> Repair Kits



**Hot Melt  
Technologies, Inc.**

No One Puts It Together Like HMT<sup>®</sup>

hotmelt-tech.com



## **Rely On HMT For All Your Hot Melt Application Needs.**

Since 1981, Hot Melt Technologies has focused on making the best hot melt equipment available and sharing our application expertise with companies just like yours. At HMT, we know the importance of the products you manufacture and package. Our equipment -- and your satisfaction with it -- is equally important to us.

Everything we provide—from melt tanks to hoses, to guns and nozzles, to spare parts and accessories—is manufactured to the highest engineering, technical, and quality standards. From basic out-of-the-box applicators to specially designed systems, you can rely on HMT to remain committed to you and your continued satisfaction.

So, if you're seeking expertise, value, convenience and satisfaction, remember ...

**No One Puts It Together Like HMT.**

[hotmelt-tech.com](http://hotmelt-tech.com)



**Hot Melt  
Technologies, Inc.**

No One Puts It Together Like HMT®

1723 W. Hamlin Road • Rochester Hills • Rochester Hills, Michigan 48309  
Phone: 248-853-2011 | Fax: 248-853-6650 | Email: [info@hotmelt-tech.com](mailto:info@hotmelt-tech.com)  
ISO 9001 – INTERNATIONAL QUALITY ASSURANCE STANDARD

©2010 Hot Melt Technologies, Inc. 6/10