

# PROFLEX G5/G9 DUAL GRID

High Performance System

220v, 1ph

## Standard Features

- ▶ Auto-Standby
- ▶ Auto-Off Timer
- ▶ Ready Delay Timer
- ▶ Manual Standby
- ▶ Set Point Limit
- ▶ Front Panel Diagnostics
- ▶ All Zone Ready
- ▶ Temp Readout, °F or °C
- ▶ ±1°F Temp Control
- ▶ Hose/Gun On/Off Control
- ▶ 2 or 4 Hose/Gun Capability
- ▶ Audible Fault Alarm
- ▶ Service Clock
- ▶ Pump On/Off Control
- ▶ Precision Flow Control

## Common Options

- ▶ #340-032 Key Lock
- ▶ #934-247 24h/7d Timer
- ▶ #921-011 Steel Cart Assembly
- ▶ #XP-922-221 OEM Interface Cable
- ▶ #XP-922-040 Remote Motor Run Cable
- ▶ #910-055 Pump Pressure Gauge
- ▶ ProFill Load Alert

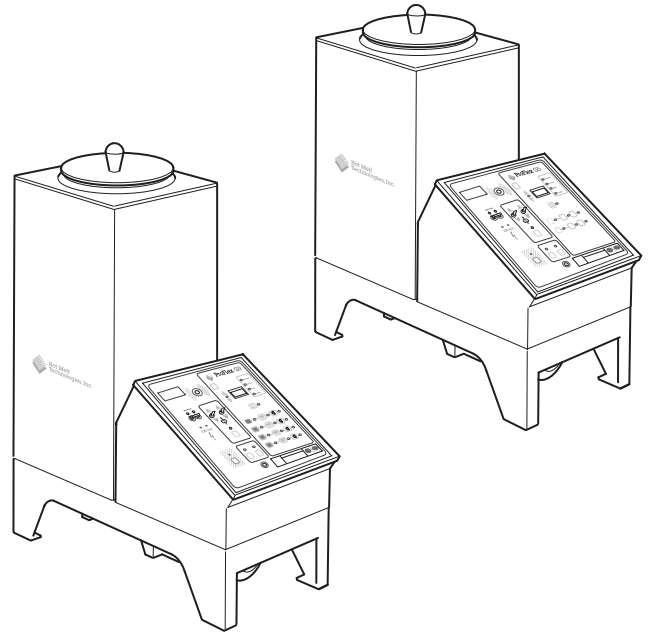

## System Configuration

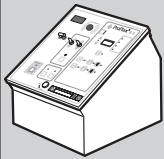
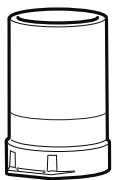
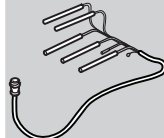
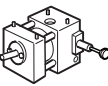
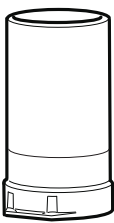
GX - XX - W - 40 - X - X					
CONTROL PACKAGE	TANK SIZE	TANK HEATER HARNESS	PUMP	MOTOR	
 G5 - 2 hose/2 gun G9 - 4 hose/4 gun	50 lb 	 W- 3000 W @ 220V	 PA-40	220v, 1ph "Blank"	
	85 lb 			CONSTANT SPEED M - 85 RPM, 1/6 HP F - 113 RPM, 1/3 HP K - 170 RPM, 1/3 HP	
				VARIABLE SPEED A - AC 0-125 RPM G - DC 0-125 RPM	

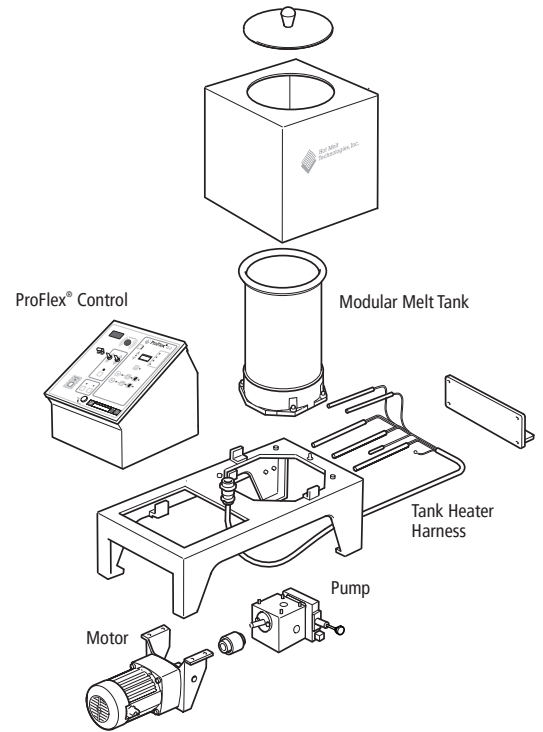

Effective Date: 2/1/2019

All prices are subject to change without notice

©2019 Hot Melt Technologies, Inc

