



# Handgun Spray Pattern Control

922-050

XP-922-050

The Hot Melt swirl spray pattern is controlled by using an air regulator and solenoid that delivers pressurized air through an air line on the heated hose, to a spray nozzle attached to the gun.

All Hot Melts do not spray alike. Each material will require specific temperature, fluid, air and nozzle adjustments to provide the desired swirl spray pattern.

### To adjust the Spray Pattern

1. Increase or decrease the air flow by adjusting the Air Regulator on the Spray Pattern Control.
  - ▶ Turn Clockwise to increase.
  - ▶ Turn Counter-Clockwise to decrease
2. Increase or decrease the adhesive flow by adjusting the Flow Control Knob.
  - ▶ Turn Clockwise to increase.
  - ▶ Turn Counter-Clockwise to decrease
3. Changing the gun's Fluid Nozzle and/or Spray Insert can vary the spray pattern throughout a wide range.
  - ▶ For options see Nozzle page or contact us.

**Note:** There is a direct relationship between the glue flow, the air pressure, and the resulting spray pattern.

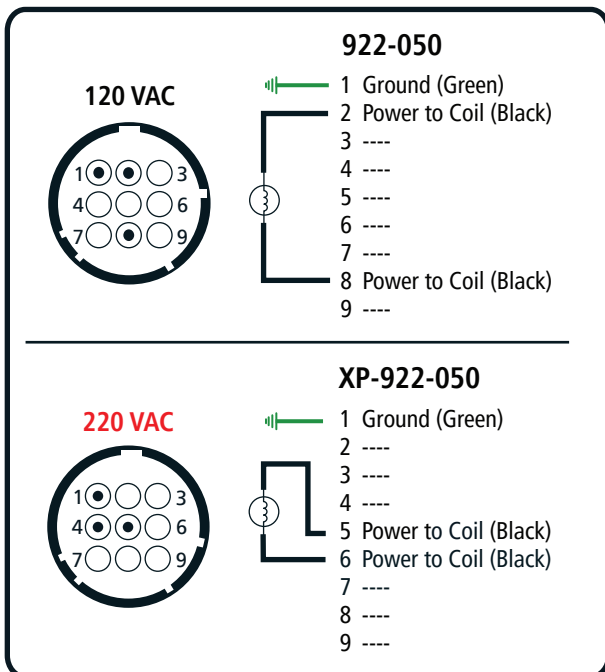

Typical Spray Pattern

