

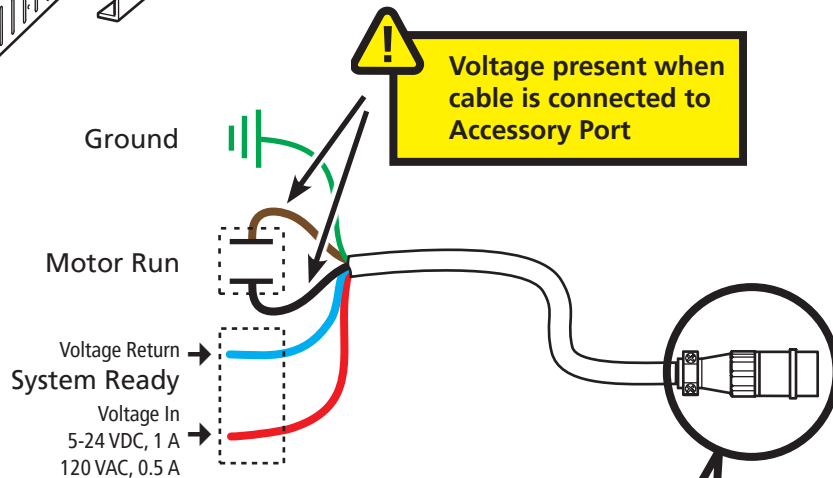

Remote Motor Run / System Ready Cable

922-121, 120 VAC
 XP-922-221, 220 VAC

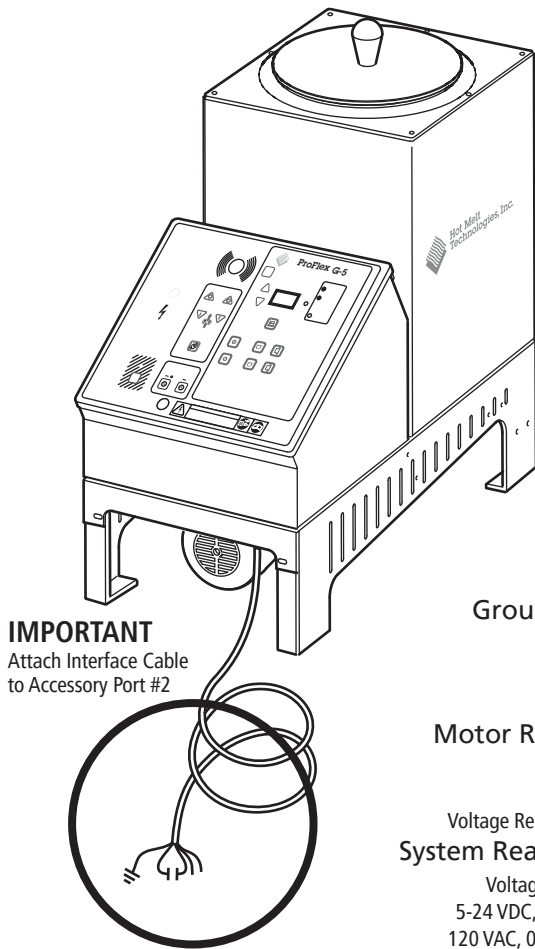

Motor Run

Requires a contact closure to activate the pump.

- 1) As provided, connect cable to Accessory Port #2 to run the pump.
- 2) As an interface, cut off butt connector and attach the brown and black wire to a manual switch, PLC, or Relay then connect cable to Accessory Port #2. Disconnect power before making changes.

System Ready

When the Hot Melt System reaches operating temperature relay contacts within the control panel close allowing an external signal to travel through the relay to complete the circuit.

