

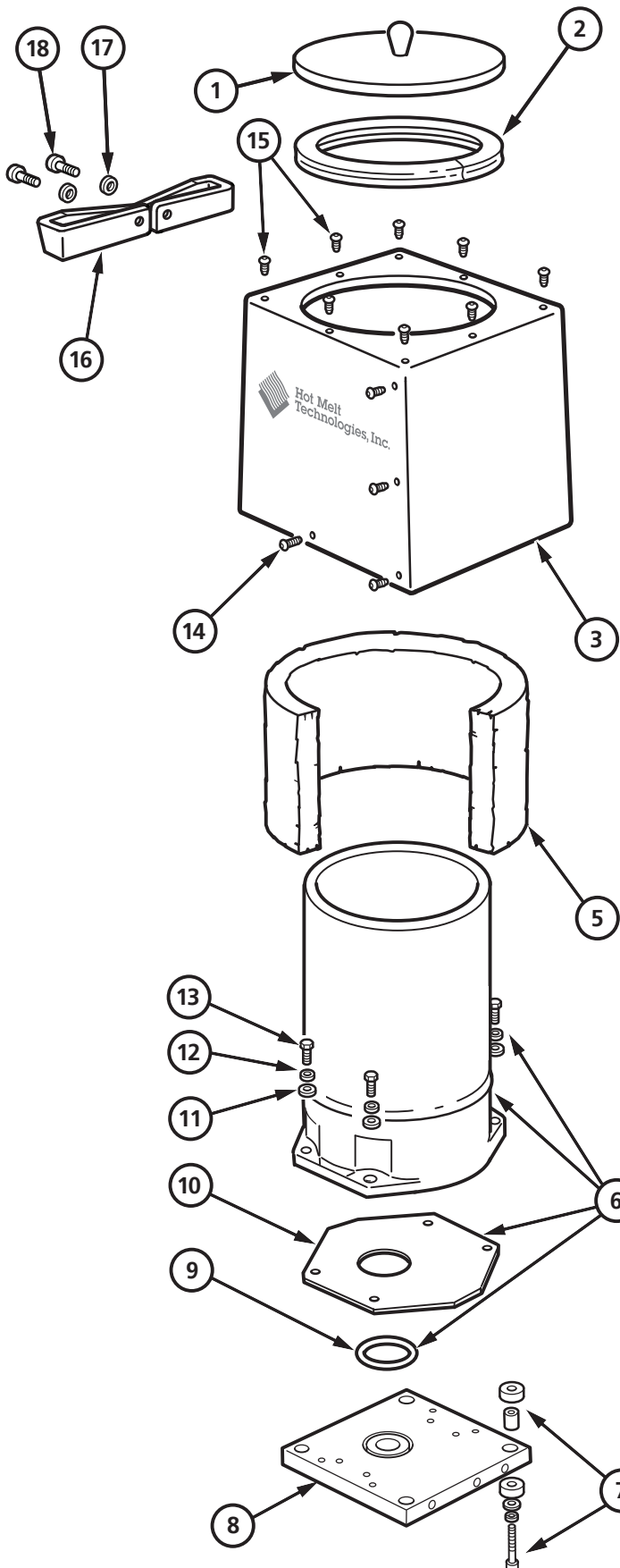



# Tank Assembly 25-50 lb, 10" dia



BILL OF MATERIALS			
ITEM	DESCRIPTION	PART NO	QTY
1a	Tank Lid 10"	911-002	1
1b	Tank Lid 10", HSA (optional)	911-023	1
2	Tank Seal 10"	510-001	1
3a	Metal Shroud - 25 lb	911-225	1
3b	Metal Shroud - 35 lb	911-235	1
3c	Metal Shroud - 50 lb	911-250	1
4a	Tank Screen 1/4" Mesh (optional)	420-061	1
4b	Tank Grid Bridge (optional)	420-062	1
5	Tank Insulation	450-003	1
6a	DFS Tank Assembly - 25 lb	911-026	1
6b	DFS Tank Assembly - 35 lb	911-036	1
6c	DFS Tank Assembly - 50 lb	911-051	1
7	Heater Plate Mounting Hardware	911-060	1
8	Tank Heater Plate	110-007	1
9	O-Ring - Teflon Encapsulated	520-031	1
10	Tank Gasket	510-025	1
11	1/4" Flat Washer	315-007	4
12	1/4" Lock Washer	316-007	4
13	1/4-20x7/8" Socket Head Cap Screw	322-104	4
14	10-32x1/2" Button Head Socket Screw	324-086	2
15	10-32x1/4" Button Head Socket Screw	324-084	14
16	Lid Caddy	330-135	1
17	1/4" Lock Washer	316-007	2
18	1/4-20x1/2" Button Socket Screw	324-137	2

Recommended for low viscosity products only.  Recommended for high viscosity, high gravity products. 