

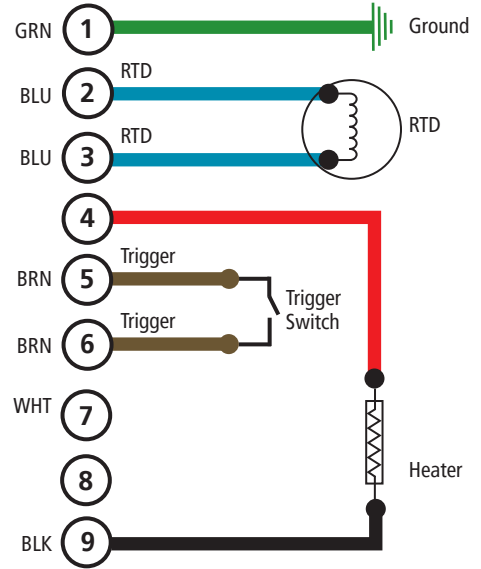

XP 500 Series Handguns 220 VAC

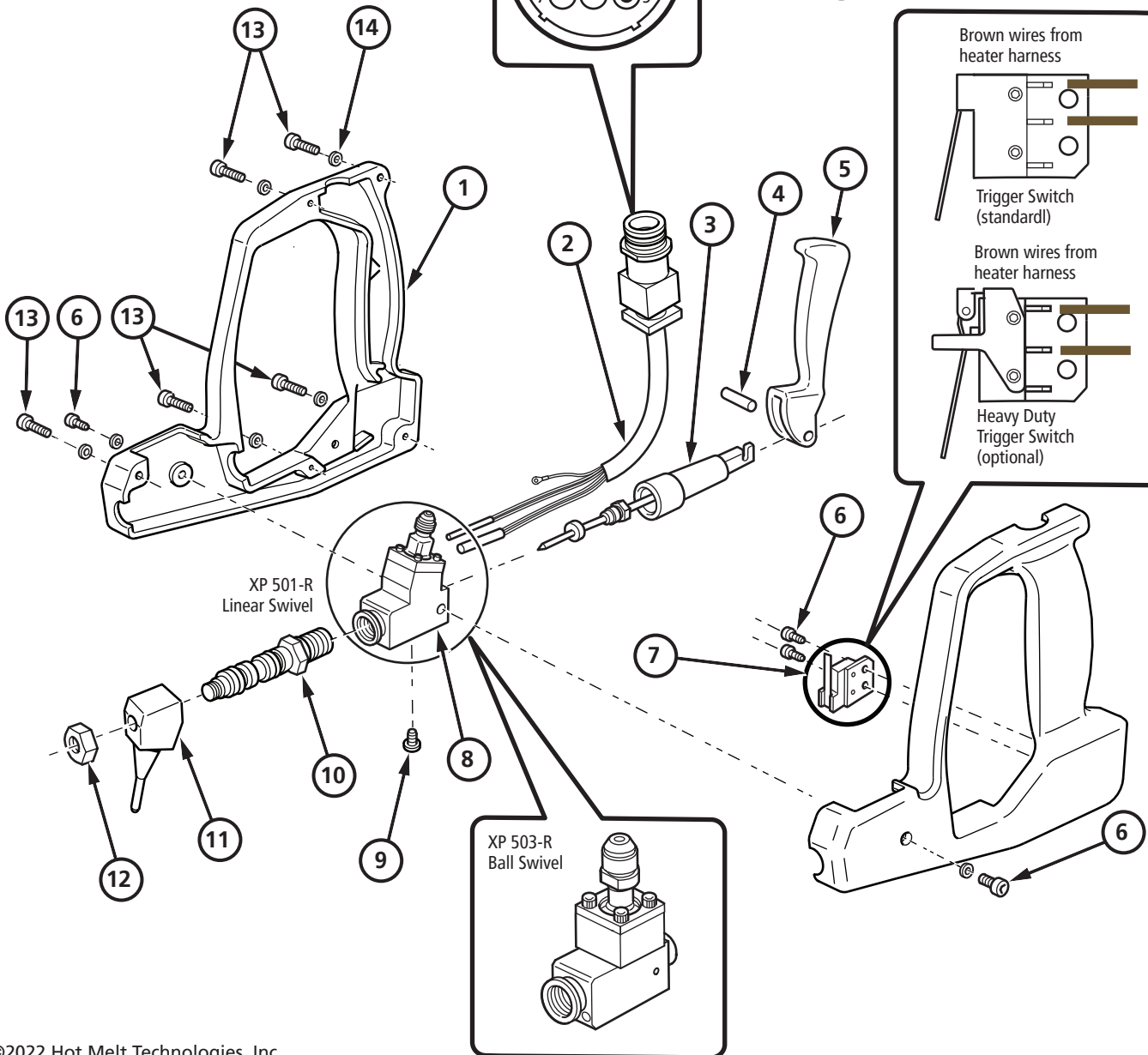

Pin Number Connection

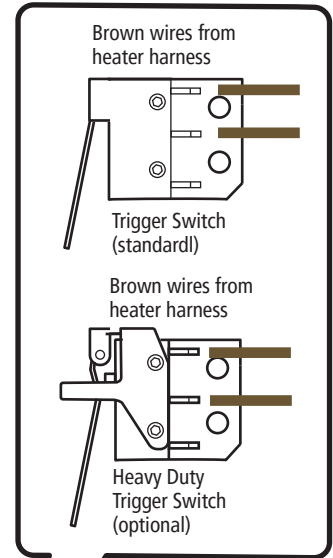
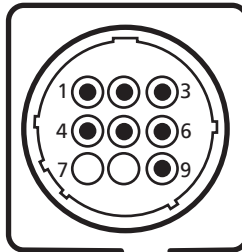



XP 500 Series Handguns **220 VAC**



Sticker
340-028

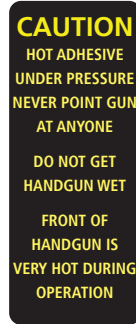

Sticker
340-029

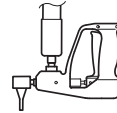

YOUR GUN CONFIGURATION

In-Line Hose Entry



XP-501-R, Linear Swivel
In-Line Hose Entry



XP-503-R, Ball Swivel
In-Line Hose Entry

BILL OF MATERIALS				XP-501-R	XP-503-R
ITEM	DESCRIPTION	PART NO	QTY		
1	Handgun Body (In-Line)	125-001	1	●	●
2a	DFS Heater Harness (In-Line) 75 W	912-200	1	●	●
2b	DFS Heater Harness (In-Line) 150 W	912-205	1	○	○
3	DFS Needle Assembly (In-Line)	912-061	1	●	●
4	Trigger Pivot Pin	300-018	1	●	●
5	Trigger	125-004	1	●	●
6	6-32 X 1/4" Socket Head Cap Screws	322-002	4	●	●
7a	Trigger Switch (standard)	912-550	1	●	●
7b	Trigger Switch Heavy Duty (optional)	912-551	1	○	○
8a	DFS Heater Body With Ball Swivel	912-545	1		●
8b	DFS Heater Body With Linear Swivel	912-547	1	●	
9	6-32 X 1/8" Socket Head Cap Screw	322-001	1	●	●
10	Needle Seat	156-010	1	●	●
11	Nozzle	See Nozzles	1	●	●
12	Retaining Nut	310-026	1	●	●
13	6-32 X 1/2" Socket Head Cap Screws	322-004	5	●	●
14	Handgun Assembly Washer	125-035	7	●	●

● Standard
○ Optional

